



Volvo Construction Equipment

A60H

Volvo Articulated Haulers • 60.6 ton • 626 hp, net



Pure uptime

Get continuous production with this bigger, durable and superior machine – always available and ready to work. Count on superb reliability thanks to the machine’s robust design, easy service access and outstanding Volvo dealer network. Guarantee pure uptime.

Guaranteed durability

Increase your uptime using heavy-duty front and rear frames, hitch and wet disk brakes. Volvo proven durability and the support of extensive warranty options means you never need to worry about getting the job done. Strength and durability are hallmarks of the Volvo articulated hauler.



Fifty years strong

Fifty years and fifty tonnes later, Volvo is the world’s leading manufacturer of articulated haulers. We invented the concept and have been developing and building these machines for over 50 years – it has come a long way from its original 10 tonne articulated hauler. With proven success over the years, the machines include innovative technology and the renowned Volvo engine.



Service access

With industry-leading access, servicing your machine is quick and easy. The front grill swings down, opening a service platform with anti-slip steps. The electric hood opens to 90 degrees, allowing full and safe access to the engine compartment.



Volvo dealer network

The exclusive Volvo dealer network is there to support you whenever you need it. Volvo offers a number of services, local knowledge and global experience, including telematics machine monitoring – CareTrack™ and MATRIS™ – as well as superb parts availability.





UPTIME



Get ready to work with the all new A60H. Designed for heavy hauling in severe off-road operation, the machine's long service life, quality, reliability and durability is everything you expect from a Volvo. Hauling is easier and more efficient.



PROFITABILITY



Reduce cost per tonne with a higher payload. The state-of-the-art design allows for more capacity while improving fuel efficiency so you can move more for less.

Move more, make more

Increase your business's profitability by moving more for less. Industry-leading fuel efficiency, innovative technology and vital operational data tools help to optimize production and control your maintenance costs, maximising your return on investment.

High Fuel efficiency

The A60H, powered by the world-renowned Volvo engine, delivers excellent fuel efficiency without compromising on power or performance. With its fuel efficiency, this machine will increase your profitability and improve your return on investment.



Maximise your investment

Meet your targets faster with the A60H. Increase your earnings with a higher payload and greater productivity for lower cost per tonne.



Control your maintenance costs

The range of Customer Support Agreements offer preventive maintenance, total repairs and a number of uptime services. Volvo uses the latest technology to monitor machine operation and status, giving you advice to increase your profitability. By having a Customer Support Agreement you are in control of your service costs.



Operational data

Receive valuable data to improve onsite efficiency and save costs. With intelligent systems from Volvo such as MATRIS™, CareTrack™ and the On Board Weighing system, you will optimize your production and minimise your operational costs.



Bigger and bolder

Achieve astounding productivity with the A60H. This machine is the ultimate hauler, featuring 100% off-road performance, proven Volvo technology and impressive payload – contributing to sustainable operations, year after year.

Articulated hauler concept

Go where others can't. The A60H embodies the full articulated hauler concept and provides total versatility so you can access the entire jobsite and climb steeper gradients. Work in all seasons, terrains and applications using tailored machine configurations and tires, optimized for this 60 tonne machine.



The best articulated hauler

The ground-breaking A60H is the best articulated hauler on the market and the latest innovation from Volvo. With matched drivetrain, automatic drive combinations including 100% differential locks, all-terrain bogie, hydro-mechanical steering and active suspension, this machine is unbeatable.



Comfort at speed

A60H is fitted with active hydraulic front suspension – permitting high hauling speeds in tough conditions. This optimizes operator comfort and stability during travel. Move more material in a shorter time for unmatched productivity.



Load optimization

The On Board Weighing System guarantees the optimal load every cycle. This maximizes production, boosts fuel efficiency and reduces machine wear in all site conditions and operations.





PRODUCTIVITY



The A60H can move more tonnes per hour and give a 100% in all conditions. The largest articulated hauler on the market has a bigger payload for your application, delivering up to 40% more productivity.

Simply the best and the biggest

PROFITABILITY



The state-of-the-art design allows for more capacity while improving fuel efficiency so you can move more for less.

Fuel efficient Volvo engine

Powered by the world-renowned Volvo engine delivers excellent fuel efficiency without compromising on power or performance.

Fifty years strong

Fifty years and fifty tonnes later, Volvo is the world's leading manufacturer of articulated haulers.

Guaranteed durability

Increase your uptime using heavy-duty front and rear frames, hitch and wet disk brakes.

The largest articulated hauler

The ground-breaking A60H is the largest 6-wheel drive articulated hauler on the market and the latest innovation from Volvo.

PRODUCTIVITY



The A60H can move more tonnes per hour and give a 100% in all conditions.



Load optimization

The On Board Weighing System guarantees the optimal load every cycle.

OPERATOR'S CHOICE



Its comfortable cab and ease of operation, even in adverse conditions, makes operators choose this machine.

High Fuel efficiency

The A60H is powered by the world-renowned Volvo engine delivers excellent fuel efficiency without compromising on power or performance.

Service access

With industry-leading access, servicing your machine is quick and easy.

UPTIME



Designed for heavy hauling in severe off-road operation, its long service life, quality, reliability and durability is everything you expect from a Volvo.

Articulated hauler concept

Go where others can't. The machine embodies the full articulated hauler concept and provides total versatility.





OPERATOR'S CHOICE



When many other machines are onsite, most operators prefer the Volvo. Its comfortable cab and ease of operation, even in adverse conditions, makes operators choose this machine.

The ultimate operating environment

The A60H is the number one operator's choice because of its industry-leading spacious cab and comfortable work environment. Its superior comfort, control, ease of operation and safety appeals to operators, maintaining productivity all day, every day.

Total operator control

Stay in control at all times. The dump support system, downhill cruise control and load and dump brake, all help the operator to control the machine for extra productivity and safety.



Operator comfort

Feel comfortable and spend more time in the A60H. The centrally positioned operator, superior steering, excellent suspension, low noise levels, climate control, space and visibility, reduce operator fatigue for more effective operations.



Ease of operation

The ergonomic, comfortable controls are easy to understand and suit all operators, combined with automatic functions for increased ease of operation.



Safety

A number of safety features such as superior visibility and efficient lighting help to keep the operator and people working around the machine safe in the most demanding working environments – whether it's the operator, trainers, mechanics or site workers.



A60H in detail

Engine

V-ACT, 16 liter, 6-cylinder straight VGT (Variable Geometry Turbocharged) diesel engine with 4 valves per cylinder, overhead camshaft and electronically controlled unit injectors. It has wet replaceable cylinder liners and replaceable valve guides and valve seats.

The engine has cooled EGR (Exhaust Gas Recirculation) and exhaust after treatment with EAT-Muffler (Exhaust After treatment) including DOC (Diesel Oxidation Catalyst), DPF (Diesel Particulate Filter) and SCR (Selective Catalytic Reduction) with an electronically controlled UDS (Urea Dosing System). T4f/Stage IV after treatment system features passive DPF regeneration with an AHI (After treatment Hydro carbon Injection) device as back up.

Engine model	Volvo	D16J
Max power - SAE J1995 Gross	kW (hp)	470 (630)
at engine speed	r/min (r/s)	1,800 (30)
Flywheel power - ISO 9249, SAE J1349 Net	kW (hp)	467 (626)
at engine speed	r/min (r/s)	1,800 (30)
Max torque - SAE J1995 Gross	Nm (ft lbf)	2,960 (2,183)
Max torque - ISO 9249, SAE J1349 Net	Nm (ft lbf)	2,942 (2,170)
at engine speed	r/min (r/s)	1,050 (17.5)
Displacement	l (in³)	16.1 (982)

Electrical System

All cables, sockets and pins are identified. Cables are enclosed in plastic conduits and secured to main frame. Halogen lights. Prewired for options. Connectors meet IP67 standard for water-proofing as necessary.

Voltage	V	24
Battery	V	2x12
Battery capacity	Ah	2x225
Alternator	kW/A	2.264/80
Starter motor	kW	9

Drivetrain

Torque converter with built-in lock-up function.
Transmission: Fully automatic Allison planetary transmission with 6 forward gears and 2 reverse gears. Internal torsional damper in the torque converter.
Dropbox: Volvo-developed, in-line design with high ground clearance and 100% longitudinal "dog clutch" type differential lock.
Axles: Heavy duty, purpose built Volvo design with fully floating axle shafts, planetary type hub reductions and 100% dog clutch type diff-lock.
Automatic traction control system (ATC).

Torque converter		1.85:1
Transmission	Volvo	6630 ORS
Dropbox	Volvo	IL3 ATC
Axles	Volvo	AHW80

Brake System

Fully hydraulic, wet multiple disc brakes with enclosed, forced oil-cooled multiple discs on all wheels. Two circuit brake system. Complies with ISO 3450 at total machine weight.

Circuit division: One circuit for front axle and one for bogie axles.
Parking brake: Spring-applied disc brake on the propeller shaft, designed to hold a loaded machine on a grade of up to 18%. When the parking brake is applied, the longitudinal differential is locked.

Retarder: Service brake retarder function and Volvo Engine Brake (VEB).

Steering System

Hydro-mechanical articulated steering, self compensating design.
Two double-acting steering cylinders.
Steering angle: 3,4 steering wheel turns lock-to-lock, ±45°.
Steering system, including secondary steering fulfills ISO 5010.

Chassis

Frames: box type, heavy duty. High strength steel, robot welded.
Rotating hitch: 100% maintenance free, fully sealed, with permanently greased tapered roller bearings.

Cab

Mounted on rubber pads. Ergonomically designed. Easy entry and exit. Wide angle forward view.
Operator centrally positioned above the front axle. Adjustable operators seat with retractable seat belt.
Tilt/telescopic steering wheel. Ergonomically positioned controls. Filtered air. Optional climate control system.
Operator communication system: Contronics.
Large color display, user-friendly and easy-to-understand information, all vital machine functions are constantly monitored.
Instructor seat with seat belt.
Safety: ROPS/FOPS standards approved according to ISO3471, SAE J1040 / ISO3449, SAE J231.

Sound level in cab (ISO 6396) - LpA	dB(A)	72
External sound level (ISO 6395) - LwA	dB(A)	113
Internal sound level with sound kit: 70 dB(A)		
External sound level with sound kit: 111 dB(A)		

Hydraulic System

Pumps: Five variable displacement piston pumps driven by the flywheel PTO.
One ground-dependent piston pump for secondary steering mounted on the dropbox.

Two return oil filters with magnetic cores provide effective oil filtration.

System max working pressure	MPa (psi)	28 (4,061)
-----------------------------	-----------	------------

Dumping System

Patented Load and Dump Brake.
Dumping Cylinders: two single stage double acting cylinders.

Tipping angle	°	70
Tipping time with load	s	12
Lowering time	s	10

Body

Plate thickness

Front	mm (in)	8 (0.31)
Sides	mm (in)	14 (0.55)
Bottom	mm (in)	16 (0.63)
Chute	mm (in)	16 (0.63)

Material

Yield strength	N/mm² (psi)	1,000 (145,038)
Tensile strength	N/mm² (psi)	1,250 (181,297)

Load Capacity

Standard Body

Load capacity	kg (sh tn)	55,000 (60.6)
Body, struck	m³ (yd³)	25.8 (33.7)
Body, heaped 2:1	m³ (yd³)	33.6 (43.9)

With overhung tailgate

Body, struck	m³ (yd³)	26.5 (34.7)
Body, heaped 2:1	m³ (yd³)	35.1 (45.9)

Specifications

REFILL CAPACITIES

Crankcase	l	gal	55	14.5
Fuel tank	l	gal	750	198.1
Cooling system	l	gal	75	19.8
Brake cooling system	l	gal	131	34.6
Transmission	l	gal	58	15.3
Dropbox	l	gal	12	3.2
Axles, front/bogie	l	gal	74/147	19.5/38.8
Hydraulic tank	l	gal	198	52.3
DEF	l	gal	60	15.9

OPERATING WEIGHT UNLOADED

Tires	33.25R29			
Front	kg	lb	22,750	50,155
Rear	kg	lb	21,000	46,297
Total	kg	lb	43,750	96,452
Payload	kg	lb	55,000	121,254

Operating weight includes all fluids and operator

TOTAL WEIGHT

Tires	33.25R29			
Front	kg	lb	28,900	63,714
Rear	kg	lb	69,850	153,993
Total	kg	lb	98,750	217,706

GROUND PRESSURE

Tires	33.25R29			
Unloaded				
Front	kPa	psi	125	18.1
Rear	kPa	psi	58	8.4
Loaded				
Front	kPa	psi	159	23.1
Rear	kPa	psi	193	28

SPEED

Forward				
1	km/h	mph	6.5	4
2	km/h	mph	9.7	6
3	km/h	mph	12.9	8
4	km/h	mph	19.2	11.9
5	km/h	mph	25.9	16.1
6	km/h	mph	54.9	34.1
Reverse				
1	km/h	mph	5	3.1
2	km/h	mph	7.5	4.7

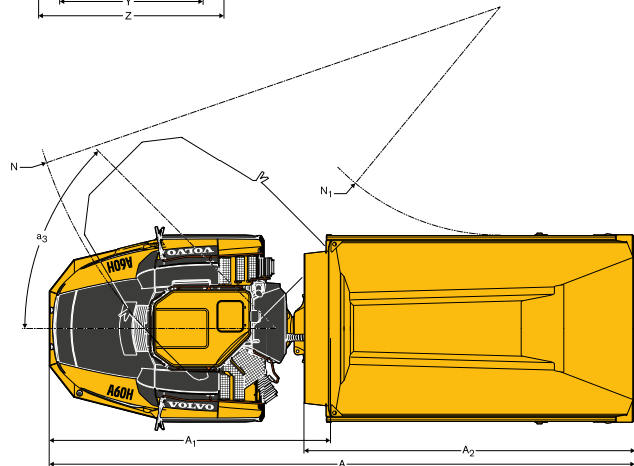
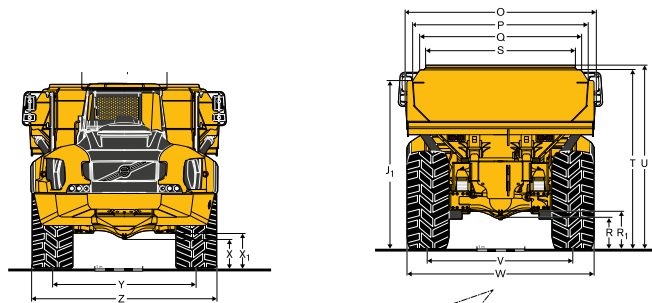
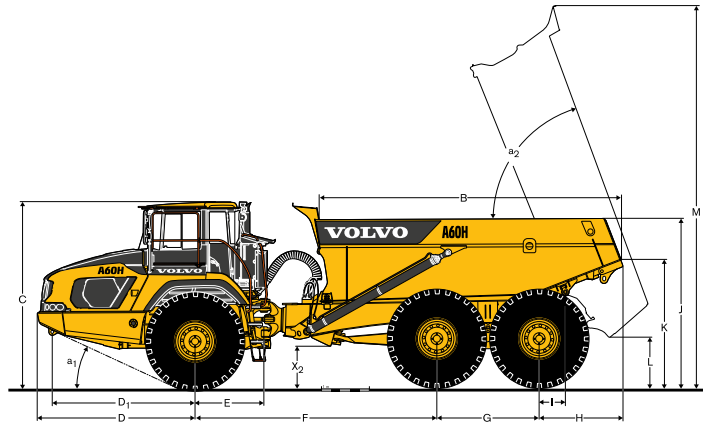

DIMENSIONS

Pos	Unit	A60H	
A	mm ft in	12,225	40'1"
A ₁	mm ft in	5,872	19'3"
A ₂	mm ft in	6,900	22'8"
B	mm ft in	6,310	20'8"
C	mm ft in	3,852	12'8"
C ₁	mm ft in	1,772	5'10"
D	mm ft in	3,293	10'10"
D ₁	mm ft in	2,986	9'10"
E	mm ft in	1,440	4'9"
F	mm ft in	5,050	16'7"
G	mm ft in	2,140	7'0"
H	mm ft in	1,743	5'9"
I	mm ft in	541	1'9"
J	mm ft in	3,510	11'6"
K	mm ft in	2,658	8'9"
L	mm ft in	1,030	3'5"
M	mm ft in	7,960	26'1"
N	mm ft in	10,014	32'10"
N ₁	mm ft in	4,761	15'7"

DIMENSIONS

Pos	Unit	A60H	
O	mm ft in	3,989	13'1"
P	mm ft in	3,673	12'1"
Q	mm ft in	3,370	11'1"
R	mm ft in	677	2'3"
R ₁	mm ft in	778	2'7"
S	mm ft in	3,126	10'3"
T	mm ft in	3,734	12'3"
U	mm ft in	3,833	12'7"
V	mm ft in	3,010	9'11"
W	mm ft in	3,884	12'9"
X	mm ft in	601	1'12"
X ₁	mm ft in	727	2'5"
X ₂	mm ft in	845	2'9"
Y	mm ft in	3,010	9'11"
Z	mm ft in	3,884	12'9"
a ₁	°		24.9
a ₂	°		70
a ₃	°		45

A60H: Unloaded machine with 33.25R29 tires.

Equipment

STANDARD EQUIPMENT

Safety

Anti-slip steps and platforms
 Dump body lock
 Handrails on steps and platforms
 Hazard lights
 Horn
 Protective grill for cab rear window
 Rear-view mirrors
 Retractable 3-inch safety belt
 ROPS/ FOPS protected Care Cab
 Secondary steering
 Steering joint lock
 Windshield washers
 Windshield wipers with interval function
 Dump support system

Drivetrain

6x4 and 6x6 automatically engaged drive modes
 Dog clutch type 100% diff-locks in all axles
 Full automatic transmission
 Two stage dropbox with longitudinal diff-lock
 Torque converter with automatic lock-up

Engine

Direct injected, electronically controlled, turbocharged, intercooled
 Grouped oil filters, for ease of change
 Preheater for easier cold starts
 VEB (exhaust retarder EPG + compression brake)

Electrical system

80 A alternator
 Battery disconnect switch
 Extra 24 V socket for lunch cooler
 Lights:
 Back-up light
 Brake lights
 Cab lighting
 Direction indicators
 Headlights
 Instrument lighting
 Parking lights
 Rear lights

Brake system

Hill assist
 Load & Dump Brake
 Retarder pedal
 Parking brake on propeller shaft
 Two circuit, fully hydraulic, wet discs on all axles

Comfort

ACC control panel
 Ashtray
 Cab heater with filtered fresh air and defroster
 Can holder /storage tray
 Cigarette lighter
 Instructor seat with seat belt
 Overhead console for radio
 Sliding window
 Space for lunch cooler
 Storage box
 Sun visor
 Tilt/telescopic steering wheel
 Tinted glass

STANDARD EQUIPMENT

Exterior

Front mudguard wideners and rear mudflaps

Operator information interface

Gauges:
 Brake pressure
 Fuel
 Speedometer
 Tachometer
 Wet disc brakes cooling oil temperature
 On Board Weighing (OBW)

Warning lights grouped and easy to read

Central warning (3 levels) for all vital functions

Central positioned information display

Automatic pre-start checks
 Clock
 Hour meter
 Operational information, easy-to-navigate menu
 Troubleshooting diagnostics

Tires

33,25R29
 800/80R29

Service and maintenance

Electrical engine hood and belly plate
 Machine Tracking Information System MATRIS
 Service platform integrated in the front grill
 Tool box

Body

Body prepared for exhaust heating and optional equipment

OPTIONAL EQUIPMENT

Safety

- Fire suppression system
- Warning triangle
- First aid kit and fire extinguisher
- Wheel chocks

Engine

- Air pre-cleaner, cyclone type
- Air pre-cleaner, oil-bath type
- Air filter, heavy duty, EON
- Engine heater, 120 V, USA
- Engine heater, 240 V
- Engine heater, diesel (Eberspächer)
- Engine auto shutdown
- Engine shutdown timer
- External emergency engine stop
- Fuel filter, extra
- High engine idle speed

Electrical system

- Headlights, LED
- Warning beacon, LED
- Working lights, LED
- Entrance light
- Anti-theft system (pin code)
- Rear view camera
- Reverse alarm

OPTIONAL EQUIPMENT

Cab

- Noise reduction kit (fulfills 2000/14/EC)
- Anchorage, operator's manual
- Cab heating/ventilation timer
- Cable kit, for cab heater 120 V/ 240 V
- HEPA cab air filter
- Bluetooth radio kit
- Rear view mirrors, adjustable, el.heated
- Seat belt XXL, non-retractable
- Sun blinds, side windows
- Universal key
- Air suspended, heated, fully adjustable seat
- Armrest for operator seat
- Headrest for operator seat

Body

- Body exhaust heating
- Front spillguard, extra
- Side extension, light material 850mm
- Tailgate, overhung, linkage-operated
- Tailgate, overhung, wire-operated
- Tailgate, underhung
- Wear plates, 450 HB

Tires

- 800/80 R29
- 33,25 R29

Service and maintenance

- Lube system, standard machine
- Tool kit

Other

- Siberian kit -40°C
- Arctic oil kit
- CareTrack
- Fast fuelling system
- Jump start connector, NATO -type

SELECTION OF VOLVO OPTIONAL EQUIPMENT

LED lighting**Tailgate****Fast fuelling****Volvo fire suppression system**

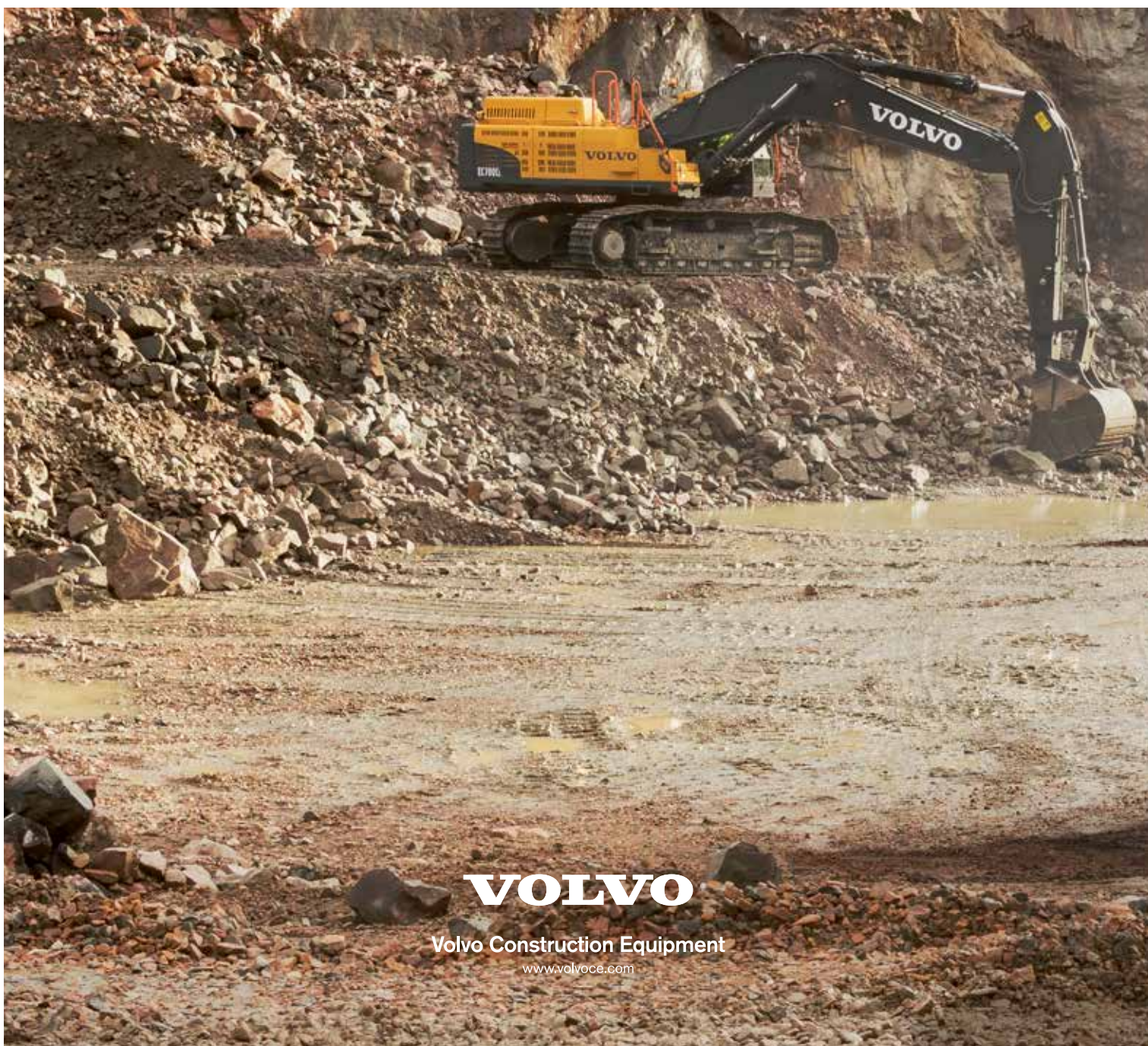

VOLVO

Volvo Construction Equipment

www.volvoce.com